

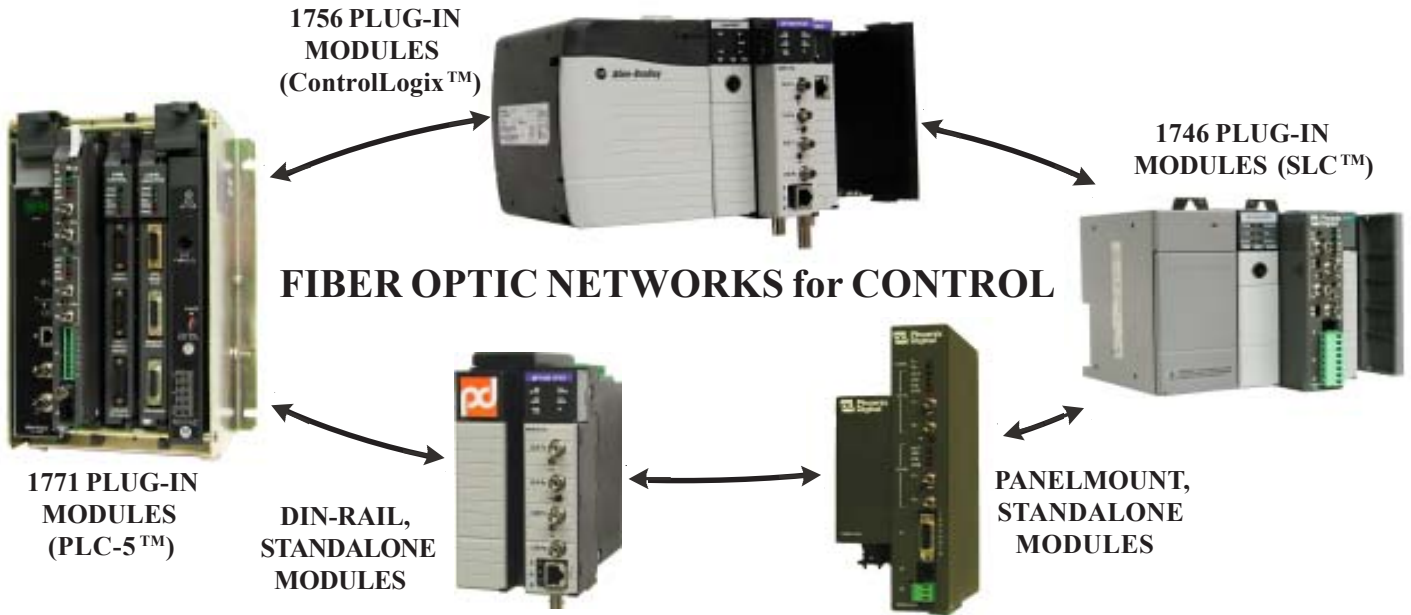

Phoenix
Digital

OPTICAL COMMUNICATION

For ROCKWELL/ALLEN-BRADLEY ControlNet™, Ethernet, FAST Ethernet, Data Highway Plus™, Remote I/O, DH-485, DF1, Modbus, and RS-232/RS-485 Communication Networks



Phoenix Digital

now provides Fault Tolerant, Redundant, Self-Healing, Fiber Optic Modules for Allen-Bradley **ControlNet, Ethernet, FAST Ethernet (ALL Protocols... TCP/IP, IP, CP, etc), Data Highway Plus, Remote I/O, DH-485, DF1, Modbus, and RS-232/RS-485 Communications.** Optical Communication Modules are available for 1771, 1746, and 1756 Chassis Installation (direct plug-in), or in modular Standalone, Industrial Enclosures for Panelmount or DIN-Rail Installation... with integral 120/220 VAC, 24 VDC, and 125 VDC power supply options.

FEATURES

- Fiber Optic Communications. . . Noise Immunity, Intrinsically Safe.
- Plugs Directly into A-B System Chassis. . . 1771, 1746, 1756 Plug-In Modules.
- Interactive Diagnostics. . . User Program Access to Network-Wide Diagnostic Status Information.
- Selectable Wavelengths. . . 850, 1300, 1550 nm.
- Dependable Data Communications. . . Fault Tolerant, Redundant Fiber Media. On-Line Fault Location and Fault Prediction.
- **UL Class I, Division 2 Rating** on all 1756 Plug-In and DIN-Rail, Standalone Modules.
- Extended Capacity, ControlNet and Ethernet. . . Multidrop 99+ ControlNet or Fast Ethernet Fiber Modules on a Bus, Ring, or Star Network.
- Supports 10/100 Mbps for Fast Ethernet. . . High Speed, Self-Healing Switch-Over for Fast Recovery of Ethernet Control Networks. Prioritized Bandwidth to Insure High Thruput for Communication to Critical Control Nodes.
- Short or Long Distance. . . 6 Feet (2 Meters) to 6 Miles (10 Kilometers) Apart - Multimode Fiber Cable Operation. Over 16 Miles (25 Kilometers) Apart - Single Mode Fiber Cable Operation. Over 60 Miles (96 Kilometers) Apart - Single Mode Fiber Cable on Fast Ethernet.
- Supports Extended DH+ and RIO Data Rates. . . 57.6K, 115.2K, and 230.4K.

DESCRIPTION

Phoenix Digital's family of Optical Communication Modules (OCMs), Optical Link Couplers (OLCs), and Optical ControlLogix Modules (OCXs) for Allen-Bradley ControlNet, Ethernet, Fast Ethernet (ALL Protocols), Data Highway Plus, Remote I/O, DH-485, DF1, Modbus, and RS-232/RS-485 networks provide the most advanced, comprehensive, fiber optic communication capabilities on the market today. Phoenix Digital's fiber optic modules provide optical communication media, transparent to the communication protocol and configurable for distribution by the user in ring, bus, star, tree, or point-to-point network installations. Fiber optic cable is now the media of preference for harsh industrial network environments due to the inherent benefits of high reliability, electrical noise immunity, and intrinsic safety. Phoenix Digital's fiber optic modules provide **continuous on-line error checking for jitter, pulsewidth distortion, carrier symmetry, and optical signal strength**. All of this, together with comprehensive network-wide diagnostics (user program accessible), optimizes the overall integrity of Allen-Bradley communication networks at-large, providing Dependable Data Communications. Optical communication network options include features not found in even the most expensive network installations:

- On-line Diagnostic Monitoring.
- Self-Healing Communication Recovery.
- Synchronous Fault Tracking for Multipoint Fault Management.
- In-Line Signal Monitoring.
- Locates Fault and Impending Fault Conditions.
- Annunciation of Low Optical Power.
- User Program Access to Network-Wide Interactive Diagnostics.
- Multidrop 99+ ControlNet or Fast Ethernet Fiber Modules on a Single Bus, Ring, or Star Network.
- UL Class I, Division 2 Rating on all 1756 Plug-In and DIN-Rail, Standalone Modules.

- Fast Ethernet Communication Designed Specifically for Control, Only from Phoenix Digital :

Overcome PLC Scan Time Limitations with Ultra-High Speed, Self-Healing Switch-Over in Ring Configurations. Fastest Self-Healing Communication Recovery available on the market today. Manage Overall Communication Bandwidth and Network Latency with Phoenix Digital's proprietary Priority Queuing System (PQS), to Insure Priority Access and Even Faster Thruput for Critical Control Nodes on the Network. Auto-Negotiation and Auto-Crossover on all Fast Ethernet Modules.

Phoenix Digital's fiber optic modules may be used to interconnect Allen-Bradley Controllers, I/O Racks, Flex I/O, Operator Interface Terminals, Computers, etc. Phoenix Digital makes all of this possible, in the price range of a conventional communication module, through application of its patented self-healing communication switch and advanced optical technologies.

OPERATION

FAULT PREDICTIVE... Phoenix Digital's fiber optic modules provide fault prediction thru diagnostic monitoring and detection of impending communication failures resulting from gradual degradation of the communication link itself. The fiber optic modules monitor for impending fault conditions by continuously measuring the actual in-line signal strength (optical power) of the data communications at the receive data inputs on the module. The fiber modules continuously compare these actual in-line measurements to preset optical power reference thresholds. If the actual in-line data communication signal strength degrades below these power thresholds the fiber modules will detect and annunciate the impending failure condition via indicators on the front of the module. Phoenix Digital's fiber optic modules also provide user program accessible interactive diagnostics

(1771 Plug-In OCM, 1746 Plug-In OLC, 1756 Plug-In OCX) and diagnostic outputs (Panelmount and DIN-Rail OCM/OLC/OCX) for detecting and locating impending fault conditions, and analog outputs for on-line optical power measurement. Thus, communication network status is continuously monitored, and impending failure conditions are located and annunciated before the communication failure actually occurs. These fiber optic network diagnostics insure on-line network integrity, and enable maintenance personnel to perform Predictive Maintenance on fiber optic ControlNet, Ethernet, Data Highway Plus, Remote I/O, DH-485, DF1, Modbus, and RS-232/RS-485 communication networks at-large!

FAULT MANAGEMENT... Phoenix Digital's fiber optic modules provide fault tolerant, redundant, self-healing communications through diagnostic monitoring of the communication signal waveforms at each node on the network, and ultra-high speed detection and isolation of points of communication failure anywhere on the network. The fiber optic modules self-heal around communication failures in ring, bus, star, tree, or point-to-point network configurations. They automatically redirect network traffic around points of failure until the failure conditions are corrected, and then automatically restore the communication network to its original traffic patterns. Thus, communication continuity is unconditionally maintained by the fiber modules in the event of either node or media failure, enabling maintenance personnel to splice/terminate/replace fiber media, add/delete nodes, etc. on-line, without disrupting network communications! In addition, Phoenix Digital's fiber optic modules provide user program accessible diagnostics (1771 Plug-In OCM, 1746 Plug-In OLC, 1756 Plug-In OCX) and diagnostic outputs (Panelmount and DIN-Rail OCM/OLC/OCX) to locate network fault conditions, providing on-line diagnostic monitoring of the communication network at-large. All of this is transparent to the operation of

ControlNet, Ethernet, Fast Ethernet (ALL Protocols), Data Highway Plus, Remote I/O, DH-485, DF1, Modbus, and RS-232/RS-485 networks.

INTERACTIVE DIAGNOSTICS... Phoenix Digital's fiber optic modules provide advanced, system-level interactive diagnostics. These diagnostics may be accessed via the PLC User Program to validate network integrity, and to assist in troubleshooting network problems:

- Detect and Locate Fault Conditions Throughout the Network.
- Trap-and-Hold, and Locate Intermittent Communication Failures.
- Detect and Locate Impending Fault Conditions Throughout the Network.
- Simulate Network Fault Conditions.
- Verify Fault Management and Overall Network Integrity.

These advanced interactive diagnostics provide the user with a powerful set of tools, greatly simplifying network start-up and on-line maintenance of ControlNet, Ethernet, Fast Ethernet (ALL Protocols), Data Highway Plus, Remote I/O, DH-485, DF1, Modbus, and RS-232/RS-485 communication networks.

EXTENDED DISTANCES... Phoenix Digital's fiber optic modules provide optional wavelength selection for extended distance applications. The economical 850 nanometer wavelength may be selected for data communication networks with less than 12,000 feet (3,650 meters) between nodes. The higher performance 1300 and 1550 nanometer multimode wavelengths may be selected for longer distance applications, extending communication distances between nodes to over 6 miles (10 kilometers). The 1300 and 1550 nanometer single mode wavelengths may be selected for extended distance applications, extending communication distances between ControlNet, Data Highway Plus, Remote I/O, DH-485, DF1, Modbus, and RS-232/RS-485 nodes to over 16 miles (25 kilometers), and between FAST Ethernet nodes to over 60 miles (96 kilometers).

INSTALLATION

Phoenix Digital's fiber optic modules may be interconnected on the fiber optic network in an active bus or fault tolerant ring configuration, using either multimode or single mode fiber optic cable. Fiber optic Channel A and B inputs and outputs may be interconnected sequentially from fiber module to fiber module to create a bi-directional, active bus. (Connection details are given in the product users manuals.) This configuration may be made fault tolerant by cross-connecting the fiber optic modules on either end of the active bus. (See Figures on pages 9 thru 12.) This effectively transforms the network into a fault tolerant, redundant, self-healing, counter-rotating ring configuration for ControlNet, Ethernet, Fast Ethernet (ALL Protocols), Data Highway Plus, Remote I/O, DH-485, DF1, Modbus, or RS-232/ RS-485 networks, without requiring any further action by the user.

SPECIFICATIONS

Fiber Optic Cable Type	: Multimode or Single Mode
Mating Connector	: ST, SC, MTRJ, LC, or SMA (SC, MTRJ, and LC available on Fast Ethernet Modules Only)
Transmit Launch Power	: -15 dBm (Typical, Multimode); -18 dBm (Single Mode)
Receive Sensitivity	: -32 dBm
Power Supply	
Plug-In Modules (Typical)	: +5 VDC, 1.5 to 1.8 Amps
Standalone Modules (Typical)	: 120/220 VAC, 24 VDC, or 125 VDC.... 8 to 10 Watts
Environmental	
Operating Temperature	: 0° to 60° C (32° to 140° F)
Storage Temperature	: -40° to 85° C (-40° to 185° F)
Relative Humidity	: 0 to 95% RH, noncondensing
Dimensions	
1771 Plug-In Modules	: Single Slot, 1771 Chassis Installation
1746 Plug-In Modules	: Single Slot, 1746 Chassis Installation
1756 Plug-In Modules	: Single Slot, 1756 Chassis Installation
Panelmount, Standalone Modules	: 10.38" H x 3.50" W x 6.14" D (26.36cm H x 8.90cm W x 15.60cm D)
DIN-Rail, Standalone Modules	: 6.10" H x 3.10" W x 5.50" D (15.49cm H x 7.87cm W x 13.97cm D)
Hazardous Location Approval	: UL and UL/C Class I, Div. 2 Groups A, B, C, D (All OCX and OCX-R modules have the US and Canadian UL Mark for use in Class I, Div. 2 Groups A, B, C, and D Hazardous Locations.)
European Union Directives	: CE

INDUSTRIAL FIBER OPTIC CABLE

Phoenix Digital provides fiber optic cable specifically designed for rugged industrial applications. Phoenix Digital's Industrial Fiber Optic Cable provides a full range of superior optical performance, rugged packaging and protection, and the physical integrity the industrial user wants and needs for ease of installation and handling.

FEATURES

- INDUSTRIAL PACKAGING OPTIONS. . .**
 Rugged Industrial Construction - Life Expectancy Exceeds 20 Years
 Double Jacketing, High Tensile Strength; Extended Temperature and Humidity Range
 Oil, Chemical, Moisture, Abrasion, and UV Sunlight Resistant
 Riser Rated (OFNR) and CSA FT-4, Passes Stringent UL 1666 Flame Test
 Plenum Rated (OFNP) and CSA FT-6, Passes Stringent UL 910 Flame Test
- WIDE VARIETY OF INSTALLATION OPTIONS. . .**
 Gel Filled Loose Tube Construction for both Indoor and Outdoor Installation
 Self-Supporting, All Dielectric Cable for Aerial Installation
 Direct Burial, Armored Cable for Underground Installation
 Low Smoke, Zero Halogen Cable for Premise Installation
 Ultra Strong, Non-Armored Cable for Deep Mine Applications
- SUPERIOR OPTICAL PERFORMANCE. . .**
 Multiple Fibers per Cable (2 to 36 Fibers); 9/125, 50/125, 62.5/125, and 200/230 Micron Sizes
 Multiple Wavelengths - Multimode and Single Mode Capability

OPTICAL PERFORMANCE

FIBER OPTIC CABLE MODEL # FOC-EXP, FOC-SSA, FOC-DBA, FOC-LSZHB, AND FOC-USNA

Fiber Type (Core/Cladding size...microns)	Mode Type	Max. Attenuation (dB/km)		Min. Bandwidth (MHz.km)		Numerical Aperture
		850 nm	1300 nm	850 nm	1300 nm	
9/125	Single Mode	N/A	.4	N/A	N/A	N/A
50/125	Multimode	3.00	1.00	800	800	0.200
62.5/125	Multimode	3.75	1.50	160	500	0.275
200/230	Multimode	7.0	N/A	15	N/A	0.370

FIBER OPTIC CABLE MODEL # FOC-RRB AND FOC-PRB

Fiber Type (Core/Cladding size...microns)	Mode Type	Max Attenuation (dB/km)		Min Bandwidth (MHz.km)		Numerical Aperture
		850 nm	1300 nm	850 nm	1300 nm	
9/125	Single Mode	N/A	.7	N/A	N/A	N/A
50/125	Multimode	3.50	1.50	800	800	0.200
62.5/125	Multimode	3.75	1.50	160	500	0.275
200/230	Multimode	12.0	N/A	15	N/A	0.370

FIBER OPTIC MODULE ORDERING INFORMATION

MODEL NUMBER⁽¹⁾	DESCRIPTION
OCX-CTN	1756 Plug-In OCX for ControlNet Networks
OCX-ETF	1756 Plug-In OCX for 10/100 Mbps Fast Ethernet Networks (ALL Protocols)
OCX-ETH	1756 Plug-In OCX for 10 Mbps Ethernet and Ethernet IP Networks
OCX-DPR	1756 Plug-In OCX for Data Highway Plus and Remote I/O Networks
OCM-CTN	1771 Plug-In OCM for ControlNet Networks
OCM-ETH	1771 Plug-In OCM for 10 Mbps Ethernet and Ethernet IP Networks
OCM-DPR	1771 Plug-In OCM for Data Highway Plus and Remote I/O Networks
OCM-DSL	1771 Plug-In OCM for DH-485 Networks
OCM-DF1	1771 Plug-In OCM for DF1 Networks
OCM-MOD	1771 Plug-In OCM for Modbus Networks
OCM-232	1771 Plug-In OCM for RS-232 Networks
OCM-485	1771 Plug-In OCM for RS-485 Network
OLC-CTN	1746 Plug-In OLC for ControlNet Networks
OLC-ETF	1746 Plug-In OLC for 10/100 Mbps Fast Ethernet Networks (ALL Protocols)
OLC-ETH	1746 Plug-In OLC for 10 Mbps Ethernet and Ethernet IP Networks
OLC-DPR	1746 Plug-In OLC for Data Highway Plus and Remote I/O Networks
OLC-DSL	1746 Plug-In OLC for DH-485 Networks
OLC-DF1	1746 Plug-In OLC for DF1 Networks
OLC-MOD	1746 Plug-In OLC for Modbus Networks
OLC-232	1746 Plug-In OLC for RS-232 Networks
OLC-485	1746 Plug-In OLC for RS-485 Networks
OCM-CBL-TF	OCM/OLC/OCX ControlNet Fault Tracking Interconnect Cable (3 ft./9 meter length).
OLC-CBL-SC	SLC 500 to OLC Interconnect Cable for DH-485 (1 ft./3 meter length).
OCM-CBL-DF	PLC-5 to OCM Interconnect Cable for DF1 (1 ft./3 meter length).
OLC-CBL-DF	SLC 500 to OLC Interconnect Cable for DF1 (1 ft./3 meter length).
OCM-CBL-A1	10 Base-T or 10/100 Base-T OCM/OLC/OCX Interconnect Cable for Ethernet or FAST Ethernet (1 ft./3 meter length).
OCX-CBL-A1	10 Base-T OLC/OCX-ETH (Port 2) Interconnect Cable for Ethernet (1 ft./3 meter length).
OCM-AUI-A1	10 Base-T Ethernet Transceiver.

Add the Following Options to the Product Model Numbers given on page 6 :

- (1) Add suffix “-85” for 12,000 feet/3,650 meters between nodes (850 nm Multimode Wavelength).
Add suffix “-13” for 32,000 feet/10 kilometers between nodes (1300 nm Multimode Wavelength).
Add suffix “-15” for 43,000 feet/13 kilometers between nodes (1550 nm Multimode Wavelength).
(The 1550 nm Multimode wavelength is not available on OLC/OCX-ETF modules.)
-

Add suffix “-P” for Panelmount, Standalone Module Enclosure.

Add suffix “-R” for DIN-Rail, Standalone Module Enclosure. (Available with OCX modules only.)

Add suffix “-D” for Real Time Diagnostic Option. (Required on OCX Modules for UL and UL/C Class I, Division 2 Rating.)

Add suffix “-ST” for ST Fiber Optic Connector Style. (Available on all fiber module types, for all optical wavelengths.)

Add suffix “-SC” for SC Fiber Optic Connector Style. (Available on OLC/OCX-ETF modules only, for all optical wavelengths.)

Add suffix “-LC” for LC Fiber Optic Connector Style. (Available on OLC/OCX-ETF modules only, for the 1300 nm and 1550 nm optical wavelengths.)

Add suffix “-MT” for MTRJ Fiber Optic Connector Style. (Available on OLC/OCX-ETF modules only, for all optical wavelengths except the 1550 nm single mode wavelength.)

Add suffix “-SMA” for SMA Fiber Optic Connector Style. (Available on all fiber module types except OLC/OCX-ETF modules, for the 850 nm optical wavelength only.)

Add suffix “-24V” for 24 VDC Operation.

Add suffix “-125V” for 125 VDC Operation.

Add suffix “-ACV” for 120/220 VAC Operation.

Add suffix “-xA1” to OCM/OLC/OCX-ETH Modules for 10 Base-T Operation and to OLC/OCX-ETF Modules for 10/100 Base-T Operation, where “x” specifies the number of 10 Base-T or 10/100 Base-T ports available on the module. (1 or 2 for OCM/OLC/OCX-ETH modules; 1, 2, or 4 for OLC/OCX-ETF 1746/1756 Plug-In Modules, and 1, 2, 3, 4, 5, or 6 for OCX-ETF-R DIN-Rail, Standalone Modules.)

Add suffix “-A2” to OCM/OLC/OCX-ETH Modules for 10 Base-2 Operation.

Add suffix “-EXT” for Networks with 28 or More OCM/OLC/OCX-CTN Modules, 10 or More OCM/OLC/OCX-ETH or OLC/OCX-ETF Modules, and 13 or more OCM/OLC/OCX-DPR Modules.

Add suffix “-FD” to OLC/OCX-ETF and OCM-MOD Modules for Full Duplex, Point-to-Point Communication.

Add suffix “-SM” for Single Mode Operation. (Available with the 1300 Nanometer Wavelength and ST, SC, LC, or MTRJ Fiber Optic Connectors; or with the 1550 Nanometer Wavelength and ST, SC, or LC Fiber Optic Connectors.)

Add suffix “-10F” to all OCM/OLC/OCX-CBL Cable Model Numbers for 10 ft./3 m. length.

Add suffix “-HUB” to OCM/OCX-CBL-A1 Cable Model Numbers for Direct Connection to HUBs.

Add suffix “-09P”, “-15P”, “-25P” to OCM-CBL-DF1 and OLC-CBL-DF1 Cable Model Numbers for 9, 15, 25 pin A-B connectors, respectively.

FIBER OPTIC CABLE ORDERING INFORMATION ⁽¹⁾

Model # FOC-XXX-YY-ZZZ

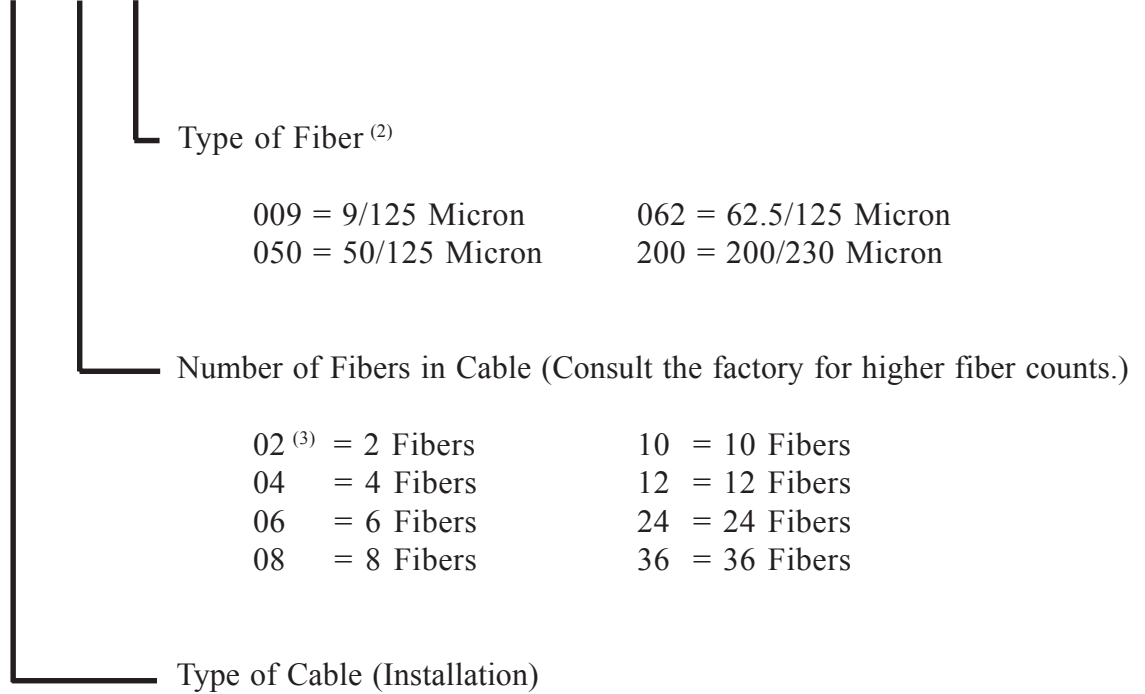

Type of Fiber ⁽²⁾

009 = 9/125 Micron	062 = 62.5/125 Micron
050 = 50/125 Micron	200 = 200/230 Micron

Number of Fibers in Cable (Consult the factory for higher fiber counts.)

02 ⁽³⁾ = 2 Fibers	10 = 10 Fibers
04 = 4 Fibers	12 = 12 Fibers
06 = 6 Fibers	24 = 24 Fibers
08 = 8 Fibers	36 = 36 Fibers

Type of Cable (Installation)

EXP	=	Extended Performance, Industrial Construction
SSA	=	Self-Supporting Aerial, All Dielectric Construction
DBA	=	Direct Burial, Armored Construction
LSZHB	=	Low Smoke, Zero Halogen Construction
USNA	=	Ultra Strong, Non-Armored Construction
RRB	=	Riser Rated Breakout Construction
PRB	=	Plenum Rated Breakout Construction

(1) Consult the factory for High Bandwidth Multimode Glass Fiber, for Extended Distance applications.
 (2) Consult the factory for other types of cable constructions, types of optical fibers, quantities of bundled fibers, and custom cables.
 (3) Specify "02F" for Flat Zipcord Breakout Construction.

Consult the Factory or Visit our Website at "www.phoenixdigitalcorp.com" for more detailed specifications on all Phoenix Digital Fiber Optic Cable Products and Services.



7650 E. Evans Rd., Bldg A
 Scottsdale, AZ 85260
 (480) 483-7393 Phone
 (480) 483-7391 Fax
 email: phxdigital@aol.com
 internet: <http://www.phoenixdigitalcorp.com>

**UL CLASS I, DIVISION 2 (HAZARDOUS LOCATIONS) 10/100 Mbps
FAST ETHERNET DUAL MEDIA RING CONFIGURATION
(FAULT TOLERANT)**

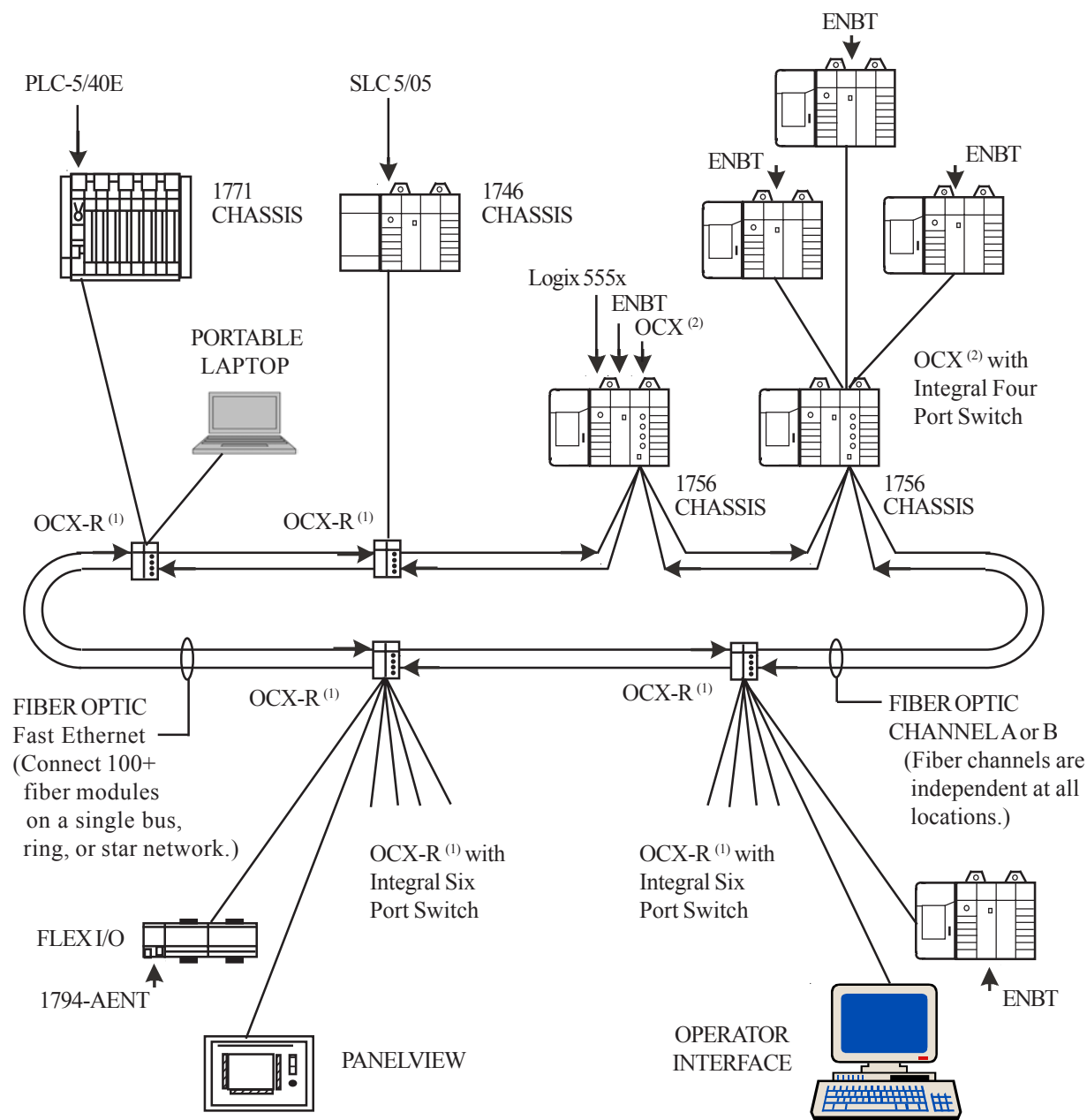

(1) OPTICAL COMMUNICATION MODULE
MODEL # OCX-ETF-13-R-D-ST-ACV-6A1
(UL CLASS I, DIV. 2)

(2) OPTICAL ControlLogix MODULE
MODEL # OCX-ETF-13-D-ST-4A1
(UL CLASS I, DIV. 2)

TYPICAL OCX-ETF INSTALLATION CONFIGURATION

**UL CLASS I, DIVISION 2 (HAZARDOUS LOCATIONS)
DATA HIGHWAY PLUS DUAL MEDIA RING CONFIGURATION
(FAULT TOLERANT)**

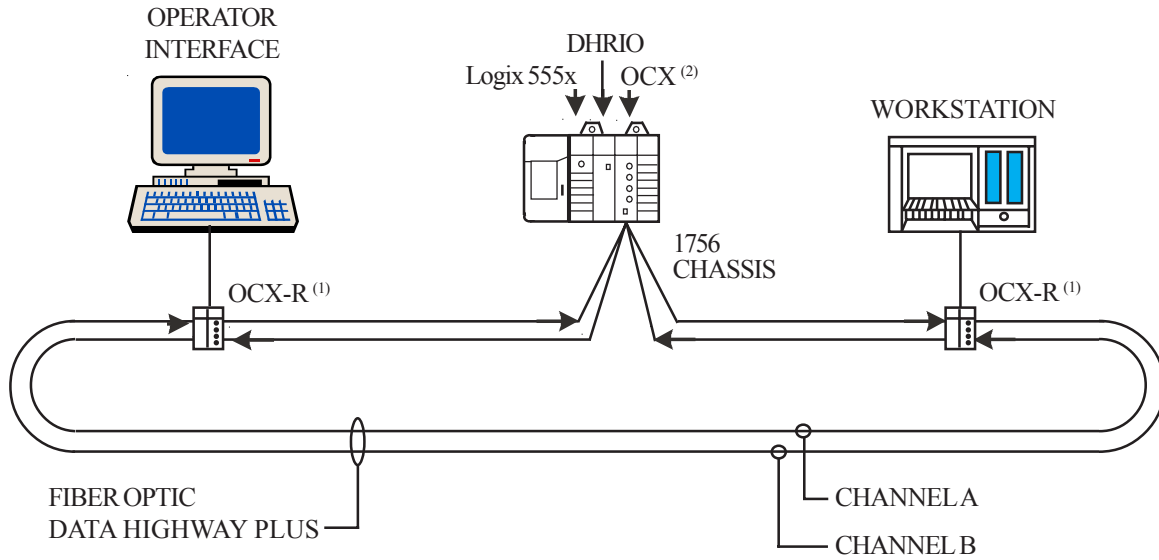

(1) OPTICAL COMMUNICATION MODULE
MODEL # OCX-DPR-85-R-D-ST-ACV
(UL CLASS I, DIV. 2)

(2) OPTICAL ControlLogix MODULE
MODEL # OCX-DPR-85-D-ST
(UL CLASS I, DIV. 2)

ETHERNET DUAL MEDIA RING CONFIGURATION (FAULT TOLERANT)

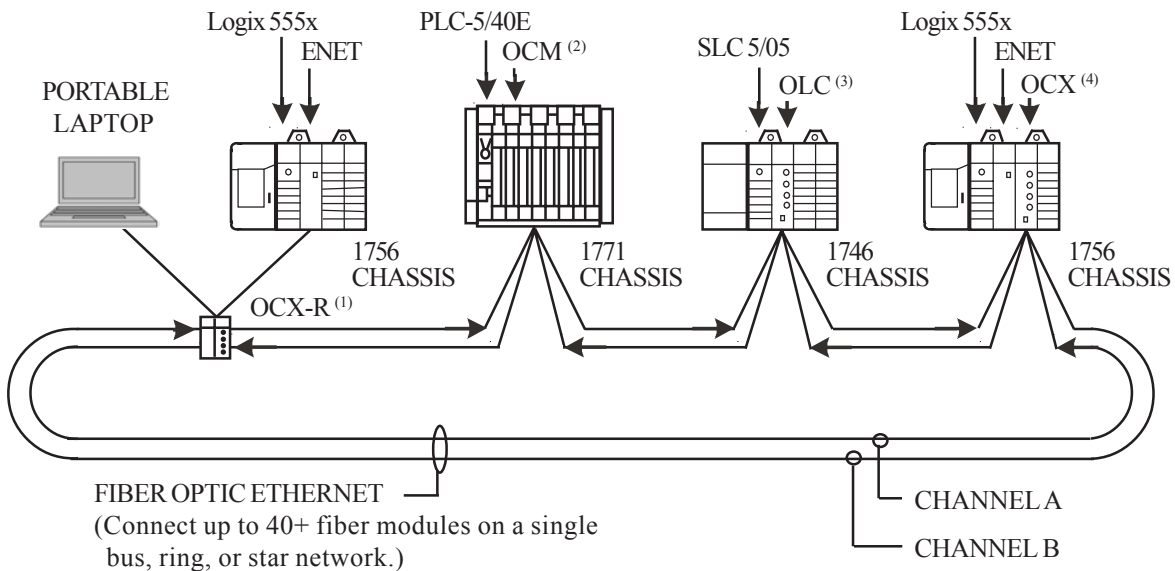

(1) OPTICAL COMMUNICATION MODULE
MODEL # OCX-ETH-85-R-D-ST-ACV-2A1
(UL CLASS I, DIV. 2)

(2) OPTICAL COMMUNICATION MODULE
MODEL # OCM-ETH-85-D-ST-2A1

(3) OPTICAL LINK COUPLER
MODEL # OLC-ETH-85-D-ST-2A1

(4) OPTICAL ControlLogix MODULE
MODEL # OCX-ETH-85-D-ST-2A1
(UL CLASS I, DIV. 2)

TYPICAL OCM/OLC/OCX INSTALLATION CONFIGURATIONS

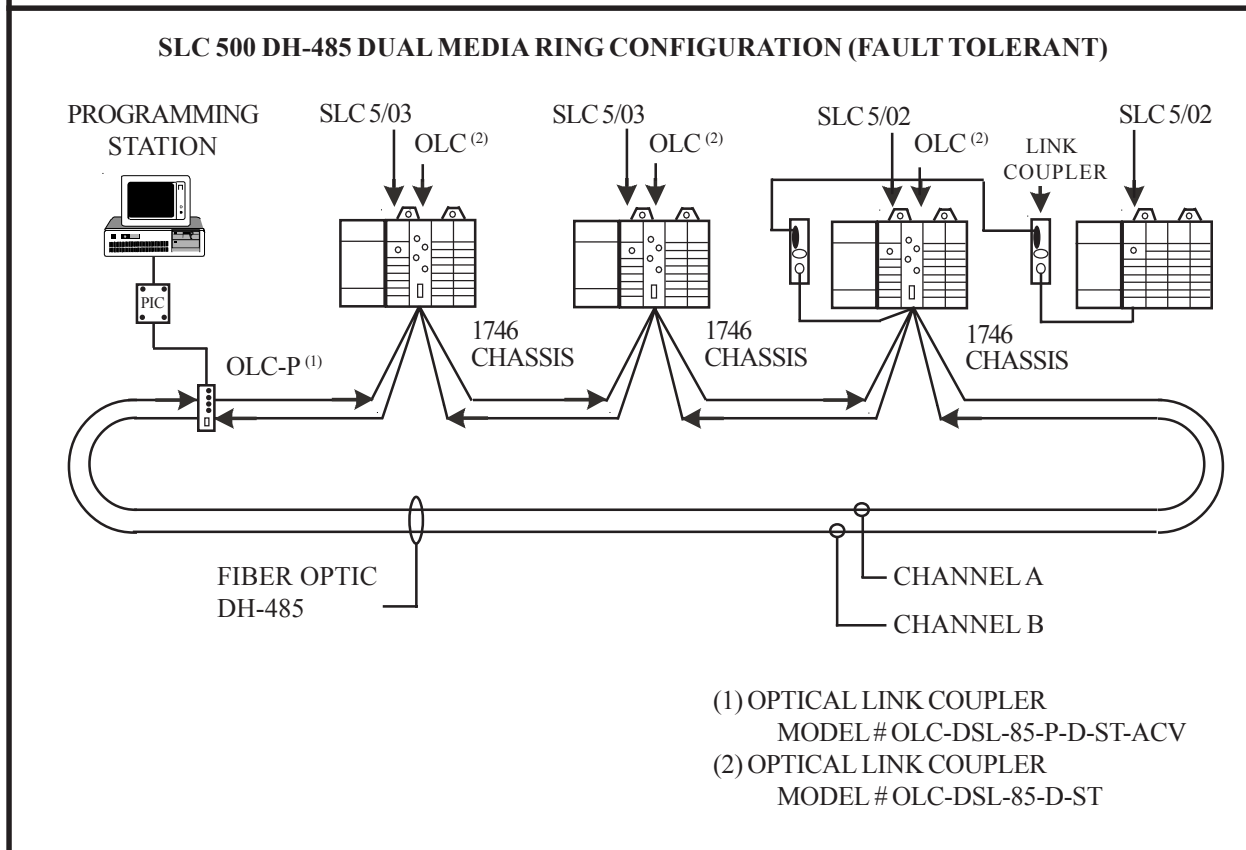
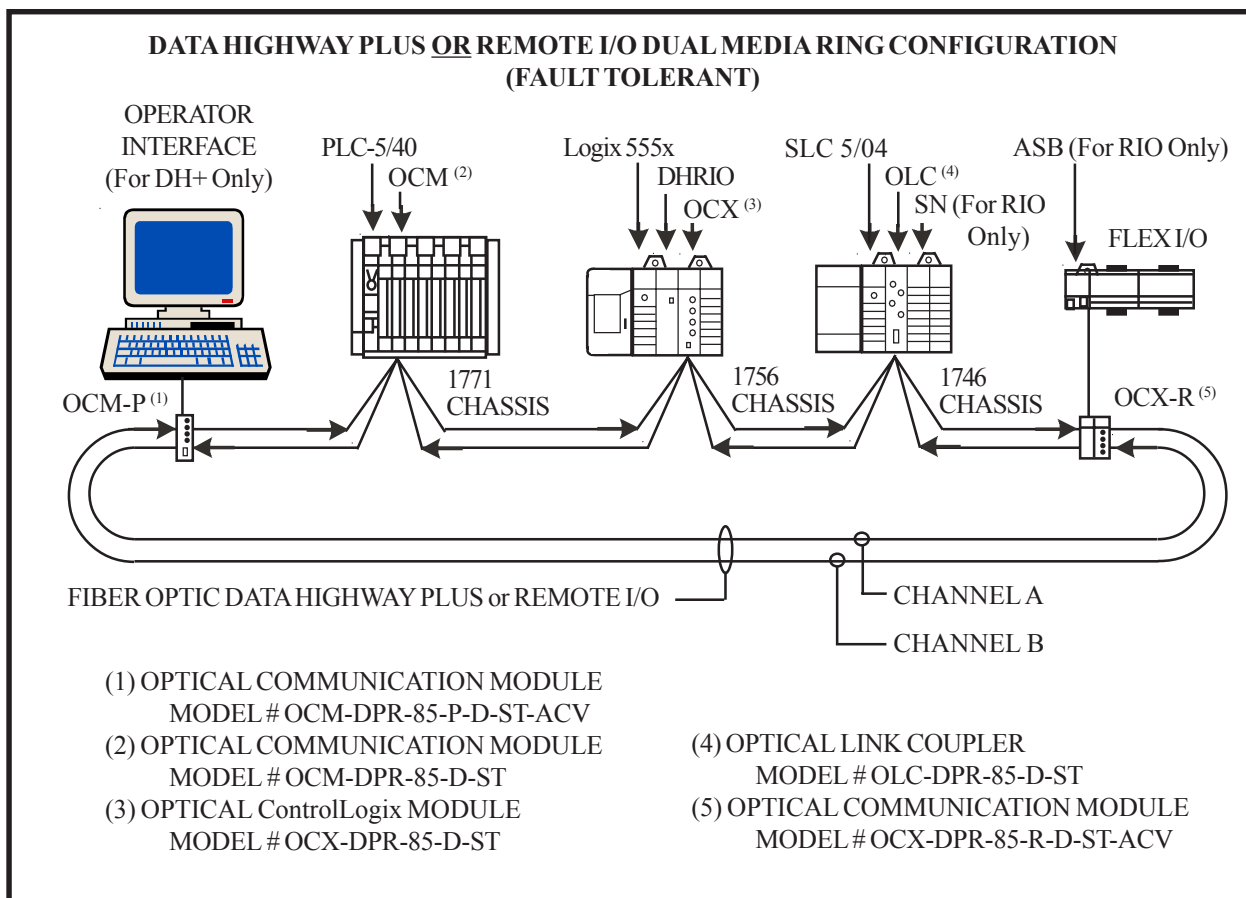

TYPICAL OCM/OLC/OCX INSTALLATION CONFIGURATIONS

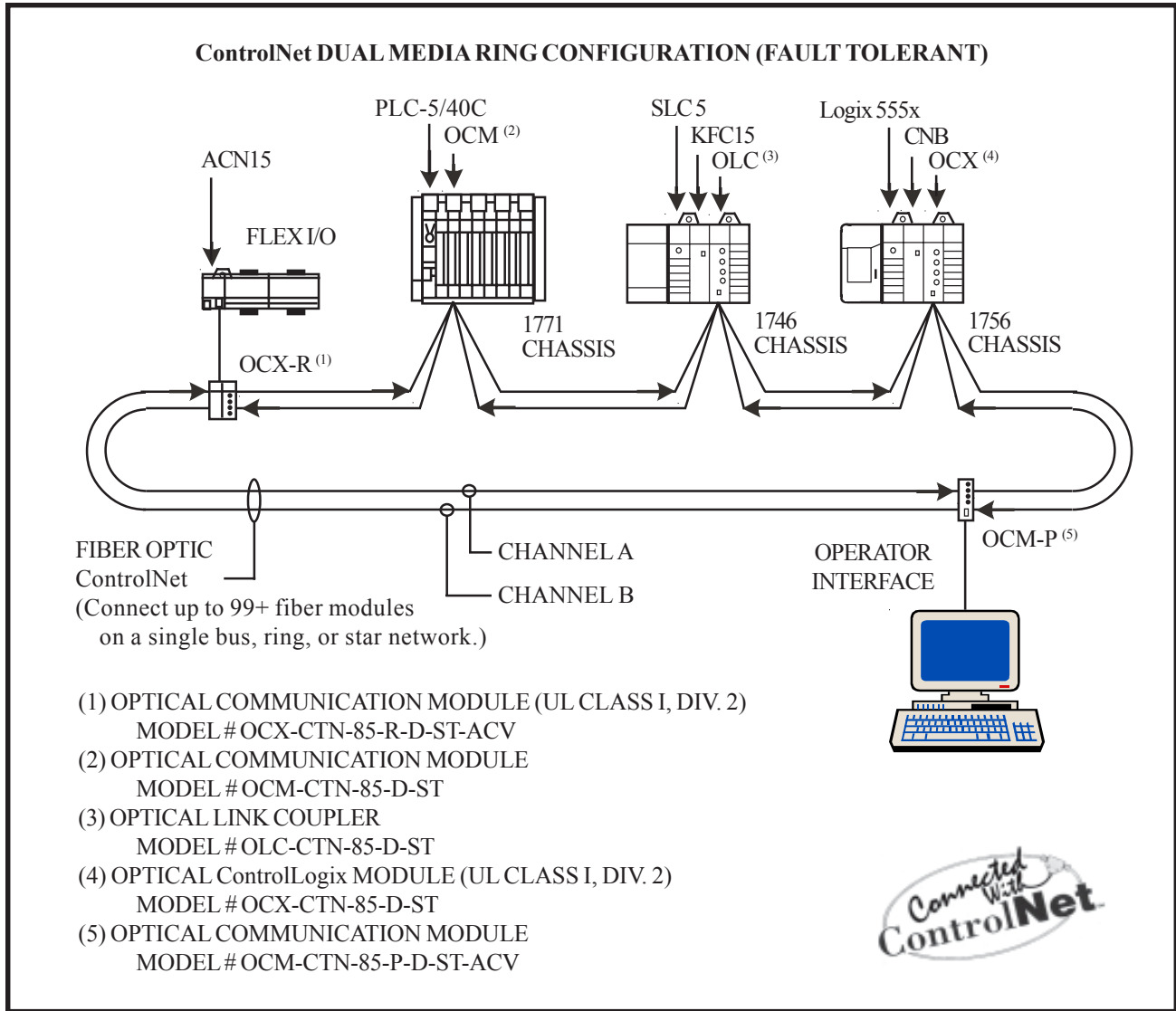

TYPICAL ControlNet OCM/OLC/OCX INSTALLATION CONFIGURATION



7650 East Evans Rd., Bldg. A
Scottsdale, AZ 85260
(480) 483-7393 Phone
(480) 483-7391 Fax
email: phxdigital@aol.com
internet: <http://www.phoenixdigitalcorp.com>



Consult factory for additional information on fiber optic modules for other Allen-Bradley networks; **multiplexers and network servers for MODBUS; Industrial Fiber Optic Cable** (indoor, outdoor, aerial, burial, etc.); Wavelength Division Multiplexers and Optical Couplers; and Optical Slip Rings.



INDUSTRIAL FIBER OPTIC CABLE

Phoenix Digital provides fiber optic cable specifically designed for rugged industrial applications. Phoenix Digital's Industrial Fiber Optic Cable provides a full range of superior optical performance, rugged packaging and protection, and the physical integrity the industrial user wants and needs for ease of installation and handling.



FEATURES

- INDUSTRIAL PACKAGING OPTIONS...

- Rugged Industrial Construction - Life Expectancy Exceeds 20 Years
- Double Jacketing, High Tensile Strength
- Extended Temperature and Humidity Range
- Oil, Chemical, Moisture, Abrasion, and UV Sunlight Resistant
- Low Smoke, Zero Halogen
- Riser Rated (OFNR) and CSA FT-4, Passes Stringent UL 1666 Flame Test
- Plenum Rated (OFNP) and CSA FT-6, Passes Stringent UL 910 Flame Test

- WIDE VARIETY OF INSTALLATION OPTIONS...

- Dry Block With Gel Filled, Loose Tube Construction for both Indoor and Outdoor Installation
- Self Supporting, All Dielectric Cable for Aerial Installation
- Direct Burial, Armored Cable for Underground Installation
- Riser and Plenum Rated Cable for Riser, Premise, and Cable Tray Installation



- SUPERIOR OPTICAL PERFORMANCE...

- Multiple Fibers per Cable (2 to 36 Fibers)
- 9/125, 50/125, 62.5/125, and 200/230 Micron sizes
- Multiple Wavelengths
- Multimode and Singlemode Capability

- FULLY COMPATIBLE WITH PHOENIX DIGITAL'S COMPLETE LINE OF INDUSTRIAL OPTICAL COMMUNICATION MODEMS FOR...

Rockwell/A-B	Modicon
Siemens/TI	Foxboro
GE Fanuc	Rosemount
Square D	Honeywell
ABB Process Automation	Omron
Kent-Taylor	Plus Many Others

EXTENDED PERFORMANCE FIBER OPTIC CABLE FOR INDUSTRIAL APPLICATIONS

FEATURES... BENEFITS:

- Extended Performance...
Suitable for Harsh Industrial Environments
- Proprietary, Polyolefin-Based Jacketing Material (No Plasticizers)...
Corrosion, Moisture, Oil, Flame, Gas, Chemical and UV Resistant
Meets the Requirements of IEEE-383 Flame Test UL 1581
- Rugged, Industrial Construction...
Life Expectancy Exceeds 20 Years
- Superior Abrasion and Flexibility to Standard PVC and Polyethylene...
Ease of Installation and Handling in Both High and Low Temperature Environments
- Gel Filled, Loose Tube Construction...
Wide Storage and Operating Temperature Range
- Dry Block Technology...
Simplifies Installation and Reduces Termination Time

INSTALLATION:

Both Indoor and Outdoor Application
Cable Tray... Crush Resistant, Low Friction Jacketing Material
Aerial... With Messenger
Burial... In Conduit

SPECIFICATIONS FOR MODEL # FOC-EXP FIBER OPTIC CABLE:

Mechanical Properties...

Fiber Quantity	Outer Diameter inches (mm)	Cable Weight lbs./1,000 ft. (kg/km)	Maximum Tension lbs. (N)		Minimum Bend Radius inches (cm)		Maximum Vertical Rise ft. (M)
			Install.	Operating	Install.	Operating	
2	0.425 (10.8)	65 (97)	600 (2670)	200 (890)	8.5 (21.6)	4.3 (10.8)	2462 (750)
4	0.425 (10.8)	65 (97)	600 (2670)	200 (890)	8.5 (21.6)	4.3 (10.8)	2462 (750)
6	0.425 (10.8)	65 (97)	600 (2670)	200 (890)	8.5 (21.6)	4.3 (10.8)	2462 (750)
8	0.425 (10.8)	65 (97)	600 (2670)	200 (890)	8.5 (21.6)	4.3 (10.8)	2462 (750)
10	0.425 (10.8)	65 (97)	600 (2670)	200 (890)	8.5 (21.6)	4.3 (10.8)	2462 (750)
12	0.425 (10.8)	65 (97)	600 (2670)	200 (890)	8.5 (21.6)	4.3 (10.8)	2462 (750)
24	0.425 (10.8)	65 (97)	600 (2670)	200 (890)	8.5 (21.6)	4.3 (10.8)	2462 (750)
36	0.454 (11.5)	77 (115)	600 (2670)	200 (890)	9.1 (23.1)	4.5 (11.5)	2078 (633)

Environmental Properties...

Storage Temperature = -40° C to +80° C
Operating Temperature = -40° C to +80° C
Relative Humidity = 0 to 100%

SELF SUPPORTING, ALL DIELECTRIC FIBER OPTIC CABLE FOR AERIAL INSTALLATION

FEATURES... BENEFITS:

- Self Supporting Installation...
Additional Strength Members Eliminate Need to Install or Lash to Messenger Cable Between Poles
- High Density Double Polyethylene Jacket...
Corrosion, Moisture, Oil, Chemical, and UV Resistant
- All Dielectric Construction...
Superior Performance When Exposed to Lightning, Electric Fields from Adjacent Power Lines, etc.
- Track Resistant...
Suitable for Installation in High Voltage Applications up to 25kv/m
- Abrasion Resistant...
Reduces Ice Build-up in Aerial Installations and Allows Longer Pulls in Wire Duct
- Gel Filled, Loose Tube Construction...
Wide Installation and Operating Temperature Range

INSTALLATION:

Outdoor Application

Aerial... No Messenger Required

Wire Duct... High Tensile Strength and Low Abrasion for Longer Pulls

SPECIFICATIONS FOR MODEL # FOC-SSA FIBER OPTIC CABLE:

Mechanical Properties...

Fiber Quantity	Outer Diameter inches (mm)	Cable Weight lbs./1,000 ft. (kg/km)	Maximum Tension lbs. (N)		Breaking Strength lbs. (N)	Minimum Bend Radius inches (cm)	
			Install.	Operating		Install.	Operating
2	0.525 (13.34)	100 (150)	1000 (4450)	2000 (8900)	7500 (33,375)	10.6 (26.6)	5.3 (13.3)
4	0.525 (13.34)	100 (150)	1000 (4450)	2000 (8900)	7500 (33,375)	10.6 (26.6)	5.3 (13.3)
6	0.525 (13.34)	100 (150)	1000 (4450)	2000 (8900)	7500 (33,375)	10.6 (26.6)	5.3 (13.3)
8	0.525 (13.34)	100 (150)	1000 (4450)	2000 (8900)	7500 (33,375)	10.6 (26.6)	5.3 (13.3)
10	0.525 (13.34)	100 (150)	1000 (4450)	2000 (8900)	7500 (33,375)	10.6 (26.6)	5.3 (13.3)
12	0.525 (13.34)	100 (150)	1000 (4450)	2000 (8900)	7500 (33,375)	10.6 (26.6)	5.3 (13.3)
24	0.525 (13.34)	100 (150)	1000 (4450)	2000 (8900)	7500 (33,375)	10.6 (26.6)	5.3 (13.3)
36	0.525 (13.34)	100 (150)	1000 (4450)	2000 (8900)	7500 (33,375)	10.6 (26.6)	5.3 (13.3)

Environmental Properties...

Storage Temperature = -40° C to +70° C

Operating Temperature = -40° C to +70° C

Relative Humidity = 0 to 100%

CRUSH RESISTANT, ARMORED FIBER OPTIC CABLE FOR DIRECT BURIAL INSTALLATION

FEATURES... BENEFITS:

- Direct Burial Installation
- Corrugated Steel Armor Bonded to Outer Jacket...
 Provides Additional Crush Strength and Rodent Protection
- MDPE Double Polyethylene Jacket...
 Corrosion, Moisture, Oil, Chemical, and UV Resistant
- Abrasion Resistant...
 Ease of Installation and Handling
- Dry Block With Gel Filled, Loose Tube Construction...
 Wide Installation and Operating Temperature Range

INSTALLATION:

Underground... Direct Burial, Conduit
Conduit, Wire Duct, and Aerial Lashing

SPECIFICATIONS FOR MODEL # FOC-DBA FIBER OPTIC CABLE:

Mechanical Properties...

Fiber Quantity	Outer Diameter inches (mm)	Cable Weight lbs./1,000 ft. (kg/km)	Maximum Tension lbs. (N)		Minimum Bend Radius inches (cm)		Maximum Vertical Rise ft. (M)
			Install.	Operating	Install.	Operating	
2	0.650 (16.5)	148 (220)	600 (2670)	200 (890)	13.0 (33.0)	9.8 (24.8)	1080 (330)
4	0.650 (16.5)	148 (220)	600 (2670)	200 (890)	13.0 (33.0)	9.8 (24.8)	1080 (330)
6	0.650 (16.5)	148 (220)	600 (2670)	200 (890)	13.0 (33.0)	9.8 (24.8)	1080 (330)
8	0.650 (16.5)	148 (220)	600 (2670)	200 (890)	13.0 (33.0)	9.8 (24.8)	1080 (330)
10	0.650 (16.5)	148 (220)	600 (2670)	200 (890)	13.0 (33.0)	9.8 (24.8)	1080 (330)
12	0.650 (16.5)	148 (220)	600 (2670)	200 (890)	13.0 (33.0)	9.8 (24.8)	1080 (330)
24	0.650 (16.5)	148 (220)	600 (2670)	200 (890)	13.0 (33.0)	9.8 (24.8)	1080 (330)
36	0.690 (17.5)	160 (238)	600 (2670)	200 (890)	13.8 (35.1)	10.4 (26.3)	1000 (305)

Environmental Properties...

Storage Temperature = -40° C to +70° C
 Operating Temperature = -40° C to +70° C
 Relative Humidity = 0 to 100%

LOW SMOKE, ZERO HALOGEN FIBER OPTIC CABLE FOR PREMISE AND RAPID TRANSIT INSTALLATIONS

FEATURES... BENEFITS:

- Halex Jacketing (OFN, UL1581)...
Zero Halogen Content, Low Toxicity, Low Smoke, and Flame Retardent
- Meets Fire Safety Tests IEEE-383, NRS 713, NES 711, ASTM E-622,
AETA D-2671-74, and IEC 754-1

INSTALLATION:

Both Indoor and Outdoor Application
Premise and Rapid Transit Installation

SPECIFICATIONS FOR MODEL # FOC-LSZHB FIBER OPTIC CABLE:

Mechanical Properties...

Fiber Quantity	Outer Diameter inches (mm)	Cable Weight lbs./1,000 ft. (kg/km)	Maximum Tension lbs. (N)		Minimum Bend Radius inches (cm)		Maximum Vertical Rise ft. (M)
			Install.	Operating	Install.	Operating	
2	0.425 (10.8)	70 (104)	600 (2670)	200 (890)	21.6 (8.5)	10.8 (4.3)	2286 (697)
4	0.425 (10.8)	70 (104)	600 (2670)	200 (890)	21.6 (8.5)	10.8 (4.3)	2286 (697)
6	0.425 (10.8)	70 (104)	600 (2670)	200 (890)	21.6 (8.5)	10.8 (4.3)	2286 (697)
8	0.425 (10.8)	70 (104)	600 (2670)	200 (890)	21.6 (8.5)	10.8 (4.3)	2286 (697)
10	0.425 (10.8)	70 (104)	600 (2670)	200 (890)	21.6 (8.5)	10.8 (4.3)	2286 (697)
12	0.425 (10.8)	70 (104)	600 (2670)	200 (890)	21.6 (8.5)	10.8 (4.3)	2286 (697)
24	0.425 (10.8)	70 (104)	600 (2670)	200 (890)	21.6 (8.5)	10.8 (4.3)	2286 (697)
36	0.454 (11.5)	76 (113)	600 (2670)	200 (890)	23.1 (9.1)	11.5 (4.5)	1975 (602)

Environmental Properties...

Storage Temperature = -40°C to +80°C
Operating Temperature = -40°C to +80°C
Relative Humidity = 0 to 100%

QUALITY CONTROL:

- Post Construction Fiber Testing For Attenuation and Bandwidth
- Optional Sweep Bandwidth Testing
- Quality Assurance Program meets requirements of IOCFR50, Appendix B

ULTRA-STRONG, NON-ARMORED FIBER OPTIC CABLE FOR HIGH CRUSH STRENGTH AND LONG VERTICAL RISE INSTALLATIONS

FEATURES... BENEFITS:

- Stronger than Standard Armored Cables...
Crush Strength = 1,500 lbs/inch (2,684 N/cm)
- Longer Vertical Rise...
Ideal for Deep Mine Applications
- Non-Armored Construction...
Smaller and Lighter than Standard Armored Cables
- Meets Stringent Standards...
NEC Type OFNR UL1666 Riser Rated and CSA FT-4 and FT-5
Mine Safety and Health Administration Approved MSHA-SC-P-7K-263066
Pennsylvania Bureau of Deep Mine Safety Approved ("P" Number)
- Gel Filled, Loose Tube Construction...
Wide Installation and Operating Temperature Range

INSTALLATION:

Both Indoor and Outdoor Application
Conduit, Wire Duct, and Aerial Lashing

SPECIFICATIONS FOR MODEL # FOC-USNA FIBER OPTIC CABLE:

Mechanical Properties...

Fiber Quantity	Outer Diameter inches (mm)	Cable Weight lbs./1,000 ft. (kg/km)	Maximum Tension lbs. (N)		Minimum Bend Radius inches (cm)		Maximum Vertical Rise ft. (M)
			Install.	Operating	Install.	Operating	
2	0.415 (10.50)	59 (81)	1000 (4450)	333 (1482)	8.3 (21.0)	4.1 (10.5)	3281 (1000)
4	0.415 (10.50)	59 (81)	1000 (4450)	333 (1482)	8.3 (21.0)	4.1 (10.5)	3281 (1000)
6	0.415 (10.50)	59 (81)	1000 (4450)	333 (1482)	8.3 (21.0)	4.1 (10.5)	3281 (1000)
8	0.415 (10.50)	59 (81)	1000 (4450)	333 (1482)	8.3 (21.0)	4.1 (10.5)	3281 (1000)
10	0.415 (10.50)	59 (81)	1000 (4450)	333 (1482)	8.3 (21.0)	4.1 (10.5)	3281 (1000)
12	0.415 (10.50)	59 (81)	1000 (4450)	333 (1482)	8.3 (21.0)	4.1 (10.5)	3281 (1000)
24	0.415 (10.50)	59 (81)	1000 (4450)	333 (1482)	8.3 (21.0)	4.1 (10.5)	3281 (1000)
36	0.415 (10.50)	59 (81)	1000 (4450)	333 (1482)	8.3 (21.0)	4.1 (10.5)	3281 (1000)

Environmental Properties...

Storage Temperature = -40° C to +80° C
Operating Temperature = -40° C to +80° C
Relative Humidity = 0 to 100%

RISER AND PLENUM RATED FIBER OPTIC CABLE

FEATURES... BENEFITS:

- Halex Jacketing (OFNR)...
Low Smoke, Zero Halogen, Fire Safe
- Optical Fiber Non-Conductive Riser-Rated (OFNR and CSA FT-4)...
Passes Stringent UL 1666 Flame Test
- Optical Fiber Non-Conductive Plenum-Rated (OFNP and CSA FT-6)...
Passes Stringent UL 910 Flame Test

INSTALLATION:

OFNR Fiber Optic Cable for Riser and Premise Installation
 OFNP Fiber Optic Cable for Plenum, Riser, and Premise Installation
 Breakout Installation for Cabling from Wire Closets, Equipment Racks, etc.

SPECS FOR MODEL # FOC-RRB & FOC-PRB FIBER OPTIC CABLE:

OFNR Fiber Optic Cable Mechanical Properties...

Fiber Quantity	Outer Diameter inches (mm)	Cable Weight lbs./1,000 ft. (kg/km)	Maximum Tension lbs. (N)		Minimum Bend Radius inches (cm)		Maximum Vertical Rise ft. (M)
			Install.	Operating	Install.	Operating	
2F ⁽¹⁾	0.12 x 0.24 (3.0 x 6.0)	8 (12)	224 (997)	112 (498)	2.0 (5.0)	1.0 (2.5)	N/A
2	0.286 (7.26)	33 (48)	270 (1201)	112 (498)	5.8 (14.6)	2.9 (7.3)	2715 (830)
4	0.325 (8.25)	40 (60)	400 (1780)	215 (957)	6.6 (16.6)	3.3 (8.3)	4300 (1310)
6	0.380 (9.65)	57 (84)	600 (2670)	250 (1112)	7.6 (19.4)	3.8 (9.7)	3510 (980)
8	0.445 (11.30)	78 (115)	600 (2670)	250 (1112)	9.0 (22.9)	4.5 (11.3)	2565 (780)
10	0.510 (12.95)	105 (157)	600 (2670)	250 (1112)	10.2 (26.0)	5.1 (13.0)	1900 (580)
12	0.565 (14.40)	129 (192)	600 (2670)	250 (1112)	11.4 (28.8)	5.7 (14.4)	1550 (475)
24	0.680 (17.30)	194 (288)	600 (2670)	250 (1112)	13.6 (34.6)	6.8 (17.3)	1030 (315)
36	0.780 (19.80)	212 (315)	600 (2670)	250 (1112)	15.6 (39.6)	7.8 (19.8)	945 (290)

OFNP Fiber Optic Cable Mechanical Properties...

Fiber Quantity	Outer Diameter inches (mm)	Cable Weight lbs./1,000 ft. (kg/km)	Maximum Tension lbs. (N)		Minimum Bend Radius inches (cm)		Maximum Vertical Rise ft. (M)
			Install.	Operating	Install.	Operating	
2F ⁽¹⁾	0.12 x 0.24 (3.0 x 6.0)	8 (12)	224 (997)	112 (498)	2.0 (5.0)	1.0 (2.5)	N/A
2	0.231 (5.86)	24 (35)	270 (1201)	112 (498)	4.6 (11.7)	2.3 (5.9)	3730 (1135)
4	0.272 (5.90)	30 (43)	600 (2670)	250 (1112)	5.4 (13.8)	2.7 (6.9)	2985 (910)
6	0.323 (8.20)	44 (65)	600 (2670)	250 (1112)	6.4 (16.4)	3.2 (8.2)	4545 (1385)
8	0.401 (10.19)	70 (103)	600 (2670)	250 (1112)	8.0 (20.3)	4.0 (10.2)	2855 (870)
10	0.462 (11.73)	93 (138)	600 (2670)	250 (1112)	9.2 (23.4)	4.6 (12.7)	2150 (655)
12	0.523 (13.3)	125 (186)	600 (2670)	250 (1112)	10.5 (26.6)	5.2 (13.3)	2740 (835)
24	0.620 (15.73)	150 (220)	600 (2670)	250 (1112)	12.4 (31.6)	6.2 (15.8)	1350 (410)
36	0.715 (18.15)	185 (280)	600 (2670)	250 (1112)	14.4 (36.4)	7.2 (18.2)	1085 (330)

(1) Flat Zipcord Breakout Construction

Environmental Properties...

Storage Temperature = -40° C to +80° C
 Operating Temperature = -20° C to +80° C
 Relative Humidity = 5 to 95%

OPTICAL PERFORMANCE:

FIBER OPTIC CABLE MODEL # FOC-EXP, FOC-SSA, FOC-DBA, FOC-LSZHB, AND FOC-USNA

Fiber Type (Core/Cladding size...microns)	Mode Type	Max. Attenuation (db/km)		Min. Bandwidth (MHz-km)		Numerical Aperture
		850 nm	1300 nm	850 nm	1300 nm	
9/125	Singlemode	N/A	.4	N/A	N/A	N/A
50/125	Multimode	3.00	1.00	800	800	0.200
62.5/125	Multimode	3.75	1.50	160	500	0.275
200/230	Multimode	7.0	N/A	15	N/A	0.370

FIBER OPTIC CABLE MODEL # FOC-RRB AND FOC-PRB

Fiber Type (Core/Cladding size...microns)	Mode Type	Max Attenuation (db/km)		Min Bandwidth (MHz-km)		Numerical Aperture
		850 nm	1300 nm	850 nm	1300 nm	
9/125	Singlemode	N/A	.7	N/A	N/A	N/A
50/125	Multimode	3.50	1.50	800	800	0.200
62.5/125	Multimode	3.75	1.50	160	500	0.275
200/230	Multimode	12.0	N/A	15	N/A	0.370

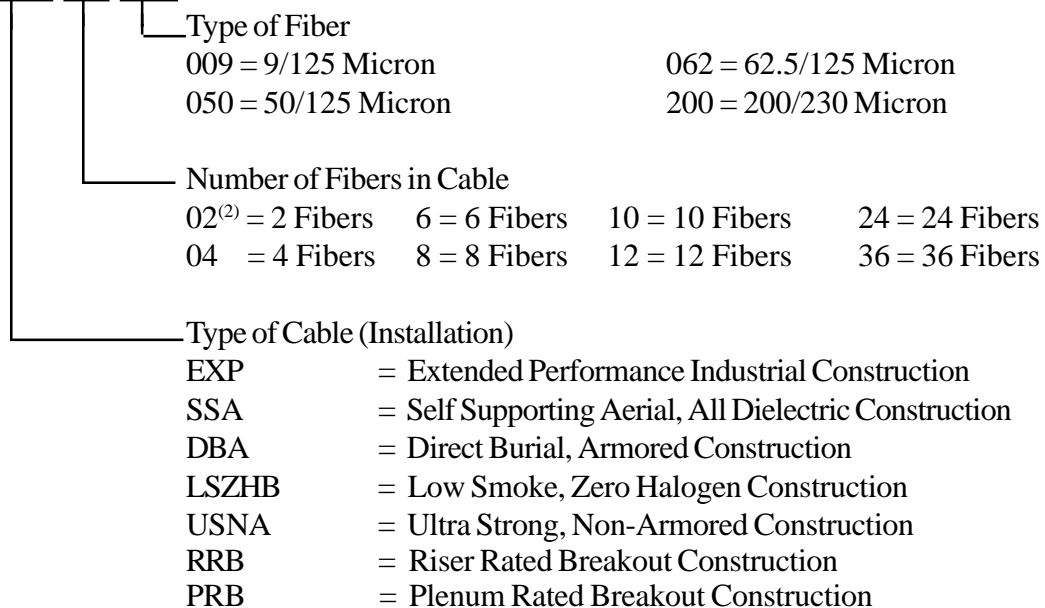
FIBER OPTIC CABLE ORDERING INFORMATION⁽¹⁾ :Model # FOC-XXX-YY-ZZZ

7650 E. Evans Rd., Bldg A

Scottsdale, AZ 85260

(480) 483-7393 Phone

(480) 483-7391 Fax

email: phxdigital@aol.com

internet: <http://www.phoenixdigitalcorp.com>